

Ignitor™ COMMON QUESTIONS AND ANSWERS

Q. What is the first thing I should check if the engine would not start?

A. Make certain all wires are connected securely to the proper terminals.

Q. The engine will not start or runs rough. Are there any tests I can do?

A. Yes, remove the red Ignitor™ wire from the coil. Connect a jumper wire from the positive side of the battery to the red Ignitor™ wire just removed from the coil. If the engine starts you have a low voltage problem (This is a very common problem). Remember this is just a test. **Not intended for permanent installation.**

Q. How can I fix a low voltage problem?

A. First, if you have an external ballast resistor, connect the red Ignitor™ wire to the ignition wire prior to the ballast resistor. Second, if you do not have a ballast resistor you must connect the red Ignitor™ wire to a 12-volt source that is controlled by the ignition switch.

Q. What type of coil do I need?

A. The Ignitor™ is compatible only with a "points style" coil. Six & eight cylinder engines require a minimum of 1.5 ohms of resistance. Four cylinder engines require a minimum of 3.0 ohms of resistance.

Q. How do I check my coil for resistance?

A. First you need an ohmmeter. Remove all the wires from the coil. Attach the meter to both the positive and negative terminals. The reading must be 1.5 ohms or greater for six and eight cylinder engines, and 3.0 ohms or greater for four cylinder engines. (Your local auto parts store can do this for you if you not have an ohmmeter)

Q. What do I do if my coil does not have enough resistance?

A. You may purchase and install a ballast resistor from your local auto parts store. You may also choose to purchase a Flame-Thrower™ 40,000-volt coil, which provides resistance internally. Note: Many vehicles come with a resistor wire or a ballast resistor. These applications do not need an additional resistor.

Q. What happens if I leave the ignition switch on when the engine is not running?

A. This can cause you coil to overheat, which may cause permanent damage to the coil and the Ignitor™.

Q. May I modify the length of the Ignitor™ wires?

A. Yes, you may cut the wires to any length your application may require. You may also add lengths of wire if needed (20-gauge wire). Please make sure all wire splice are clean and connections are secure.

Q. Will the shift interrupter on an OMC stern drive boat work with the Ignitor™?

A. The Ignitor is compatible with all OMC stern drive applications, when equipped with a "diode fix". If you purchased a kit that does not include the "diode fix" diagram, call our tech line.

Q. How can I get additional help?

A. Call our tech line (909-599-5955) for any further instructions or questions.



440 E. ARROW HIGHWAY, SAN DIMAS, CA 91773
www.pertronix.com

LIMITED WARRANTY

Manufacturer warrants to the original Purchaser of its solid state ignition system (product) that the Ignitor, magnet assembly and wiring (components) shall be free from defects in material and workmanship for a period of (30) months from the first day of use in the Purchaser's industrial truck, stationary, auto or truck engine distributor.

If within the period of the foregoing warranty manufacturer finds after inspection that the product or any component thereof is defective, manufacturer will, at its option, repair such product or component or replace them with identical or similar parts PROVIDED that within such period Purchaser

1. Promptly notifies manufacturer in writing of such defect;
2. Delivers the defective product or component to manufacturer with proof of purchase date; and
3. Has installed and used the product in a normal and proper manner consistent with manufacturer printed instructions.

THE FOREGOING LIMITED WARRANTY IS EXCLUSIVE AND IN LIEU OF ALL OTHER WARRANTIES, WHETHER EXPRESS OR IMPLIED, INCLUDING ANY IMPLIED WARRANTY OR MERCHANTABILITY OR FITNESS FOR A PARTICULAR PURPOSE.

THE FURNISHING OF A REPAIR OR REPLACEMENT COMPONENT OR COMPONENTS SHALL CONSTITUTE THE SOLE REMEDY OF PURCHASER AND THE SOLE LIABILITY OF MANUFACTURER. WHETHER ON WARRANTY, CONTRACT OR FOR NEGLIGENCE, AND IN NO EVENT WILL MANUFACTURER BE LIABLE FOR MONEY DAMAGES WHETHER DIRECT OR CONSEQUENTIAL.

PERTRONIX INC



Flame-Thrower™ LOW resistance... HIGH performance spark plug wires



The 40,000 volt Flame-Thrower™ high performance coil. IT'S HOT!



Oil filled
chrome or
stock black.
Epoxy
version
for racing.

- Maximizes energy and reliability over the full RPM range
- 40,000 available volts
- Enables larger plug gaps for greater fuel efficiency, more power
- Delivers an average of 15% more spark energy and voltage
- Legal in all 50 states and Canada
- Fits existing brackets
- Made in U.S.A

PERTRONIX

PERFORMANCE PRODUCTS



INSTALLATION INSTRUCTIONS FOR PART NUMBERS 1144A & 1162A

Before installing, please read the following important information...

1. The Ignitor is designed for **12-volt negative ground** systems.
2. The Ignitor is compatible only with a "points style" coil. Six & eight cylinder engines require a minimum of **1.5 ohms of resistance**. Four cylinder engines require a minimum of **3.0 ohms of resistance**.
3. If your ignition system presently is equipped with a **ballast resistor**, **do not remove it** (See Figure 3).
4. Caution: never use a "HEI" type coil with the Ignitor. This type of coil will damage the module, cause it to fail, and void the warranty.
5. The **red** wire from the Ignitor must be connected to the **positive** side of the coil, or a 12-volt (+) switched power source. (See Figure 2 & 3). The black wire must be connected to the negative (-) side of the coil.

1. Turn the ignition switch off and disconnect the battery negative (-) cable.
2. Remove the distributor cap and rotor. Do not disconnect the spark plug wires from the cap.
3. Examine the distributor cap and rotor for excessive wear or damage. Replace as needed.
4. Disconnect the points wire from the negative (-) terminal of the coil.
5. Remove the screws retaining the breaker plate, and lift out the entire breaker plate. The Ignitor does not require any modification to distributor. Therefore retain all parts and hardware for backup.
6. Clean all dirt and excess oil from the distributor and point cam.
7. Set the Ignitor adapter plate into the distributor housing.
8. Place the provided ground wire on one of the adapter plate screws.
9. Confirm that the Ignitor plate is flat and fits without any modification.
10. Fasten the plate into place using the original screws.
11. Install the module over the studs and down onto the adapter plate.
12. Place the loose end of the ground wire over one of the studs.
13. Use the provided lock nuts to hold module, and ground wire in place. Do not tighten the nuts all the way at this time.
14. Install magnet sleeve over distributor shaft, onto point cam. Rotate the sleeve until a slight locating position is felt before applying pressure. With sleeve lined up on point cam, press down firmly insuring sleeve is fully seated.
15. Using the plastic feeler gauge provided, adjust the air gap between the module and the magnet sleeve. The gap should be approximately 0.030".

16. Secure the module by tightening the two lock nuts.
17. Rotate the distributor shaft through a complete revolution. Verify that the magnet sleeve does not rub the module.
18. It is necessary to file a slot in the distributor cap to allow for the larger grommet.
19. Using the indentation on the rim of the cap as a guide, file away enough material so that the grommet will not be pinched when the cap is installed. A 3/16" deep by 1/4" wide slot is sufficient. (See Figure A) **IT IS IMPERATIVE THAT THIS SLOT BE FILED INTO THE CAP. FAILURE TO DO SO COULD RESULT IN AN ELECTRICAL SHORT.**
20. Insert the Ignitor black and red wires into the opening in the distributor housing. Verify the grommet is seated properly.
21. Remove the excess wire from inside the distributor housing by gently pulling the wire through the grommet. Check to insure that the wire does not interfere with any moving parts.
22. Install the distributor cap. Check to insure that all spark plug wires are seated securely in the distributor cap.
23. Attach the black Ignitor wire to the negative coil terminal.
24. For installations that do not use a primary ballast resistor, connect the red Ignitor wire to the positive coil terminal.
25. For installations that use a primary ballast resistor, connect the red Ignitor wire to the ignition switch side of the resistance. (See Figure 3.)
26. Re-connect the battery.
27. Start the engine and allow it to reach normal operating temperature. Check the timing, and adjust to the desired setting.

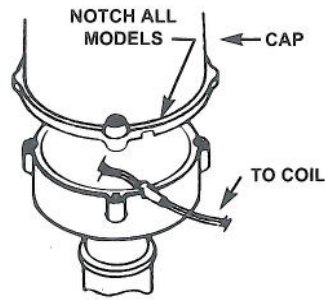

FIGURE A

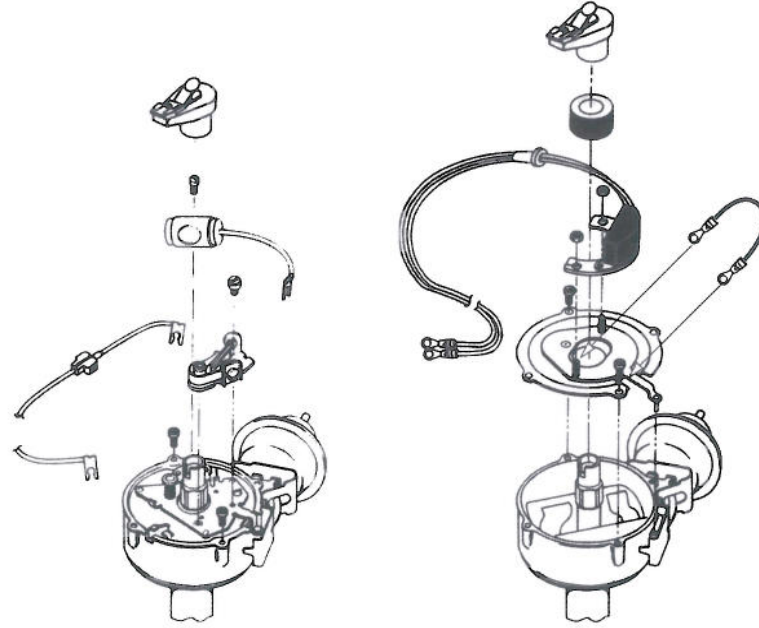

FIGURE 1
WIRING DIAGRAM
CONVENTIONAL POINTS
SYSTEM
WITH BALLAST RESISTOR

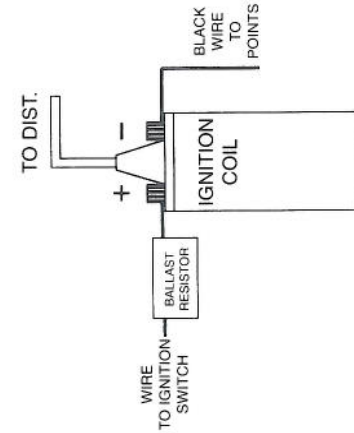

FIGURE 2
WIRING DIAGRAM
IGNITOR SYSTEM
WITHOUT BALLAST RESISTOR

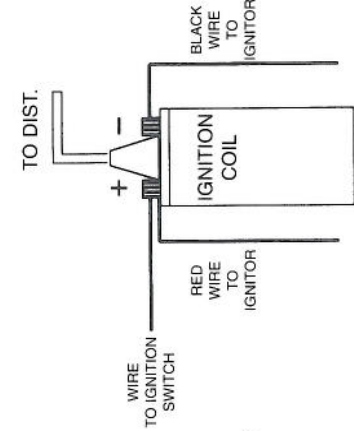
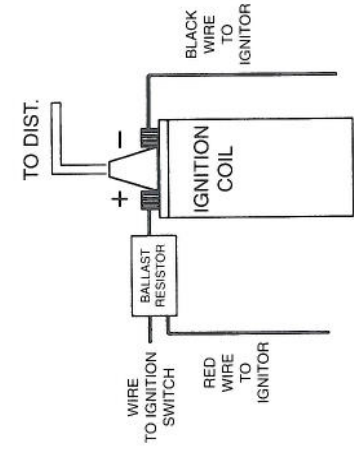

FIGURE 3
WIRING DIAGRAM
IGNITOR SYSTEM
WITH BALLAST RESISTOR



NOTE: A RESISTOR WIRE OR BALLAST RESISTOR MAY OR MAY NOT BE INCLUDED IN THE ORIGINAL EQUIPMENT. THEY ARE NOT TO BE CHANGED IN ANY WAY WITH THE INSTALLATION OF AN IGNITOR SYSTEM.